

FOR SERVICE PERSONNEL ONLY

HITACHI
HITACHI CEILING CASSETTE-UNIT AIR
CONDITIONER INSTALLATION MANUAL

Indoor Unit



RAI-25QP
RAI-35QP
RAI-50QP

- Carefully read through the procedures of proper installation before starting installation work.
- The sales agent should inform customers regarding the correct operation of installation.

Tools Needed For Installation Work

- Screwdriver
- Measuring Tape
- Knife
- Saw
- ø 65mm Power Drill
- Hexagonal Wrench Key (4mm)
- Wrench (14, 17, 19, 22, 26, 27mm)
- Gas Leakage Detector
- Pipe Cutter
- Vinyl Tape
- Pliers
- Flare Tool

SAFETY PRECAUTION

- Read the safety precautions carefully before operating the unit.
- The contents of this section are vital to ensure safety. Please pay special attention to the following sign.
- ⚠ **WARNING** Incorrect methods of installation may cause death or serious injury.
- ⚠ **CAUTION** Improper installation may result in serious consequence.

Be sure that the unit operates in proper condition after installation. Explain to customer the proper way of operating the unit as described in the user's guide.

WARNING

- Please request your sales agent or qualified technician to install your unit. Water leakage, short circuit or fire may occur if you do the installation work yourself.
- Please observe the instructions stated in the installation manual during the process of installation. Improper installation may cause water leakage, electric shock and fire.
- Make sure that the units are mounted at locations which are able to provide full support to the weight of the units. If not, the units may collapse and impose danger.
- Observe the rules and regulations of the electrical installation and the methods described in the installation manual when dealing with the electrical work. Use power cables approved by the authorities of your country.
- Be sure to use specified wire for the connection indoor and outdoor units. Please ensure that the connections are tight after the conductors of the wire are inserted into the terminals. Improper insertion and loose contact may cause over-heating and fire.
- Please use the specified components for installation work. Otherwise, the units may collapse or water leakage, electric shock and fire may occur.
- Be sure to use the specified piping set for R-410A. Otherwise, this may result in broken copper pipes or faults.
- When installing or removing an air conditioner, only specified refrigerant (R410A) shall be allowed, do not allow air or moisture to remain in the refrigeration cycle. Otherwise, pressure in the refrigeration cycle may become abnormally high so that a rupture may be caused.
- Be sure to ventilate fully if a refrigerant gas leak while at work. If the refrigerant gas comes into contact with fire, a poisonous gas may occur.
- After completion of installation work, check to make sure that there is no refrigeration gas leakage. If the refrigerant gas leaks into the room, coming into contact with fire in the fan-driven heater, space heater, etc., a poisonous gas may occur.
- Unauthorized modifications to the air conditioner may be dangerous. If a breakdown occurs please call a qualified air conditioner technician or electrician. Improper repairs may result in water leakage, electric shock and fire, etc.

CAUTION

- A circuit breaker or fuse must be installed. Without a circuit breaker or fuse the danger of electric shock exists. A main switch with a contact gap of more than 3.5mm has to be installed in the power supply line to the outdoor unit.
- Piping shall be suitably supported with a maximum spacing of 1m between the supports.
- Do not install the unit near a location where there is flammable gas. The outdoor unit may catch fire if flammable gas leaks around it.
- For installation of front panel RAI-ECPP, please follow exactly the instruction in the manual.
- Please ensure smooth flow of water when installing the drain hose.

THE CHOICE OF MOUNTING SITE (Please note the following matters and obtain permission from customer before installation).

WARNING

- The unit should be mounted at stable, non-vibratory location which can provide full support to the unit.

CAUTION

- No nearby heat source and no obstruction near the air outlet is allowed.
- The clearance distances from top, right and left are specified in figure below.
- The location must be convenient for water drainage and pipe connection with the outdoor unit.
- To avoid interference from noise please place the unit and its remote controller at least 1m from the radio, television and inverter type fluorescent lamp.
- To avoid any error in signal transmission from the remote controller, please put the controller far away from high-frequency machines and high-power wireless systems.
- The installation height of indoor unit must be 2.3m ~ 3m. Installation above 3m will affect the performance of unit.

Names of Indoor Components

No.	Item	Qty
①	Insulation pipe for flare section	2
②	Binder	4
③	Holder for Remote Controller	1
④	AAA Size Battery	2
⑤	Screw for holder of Remote Controller	2
⑥	Insulation pipe for drain pipe	1
⑦	Insulation pipe	1
⑧	Remote Controller	1
⑪	Pattern paper for positioning plate	1
⑫	Pattern paper for installation plate	1
⑬	Installation plate fixing screw (M5 X 16)	4
⑭	Blower cover	2
⑮	Corner Seal	3

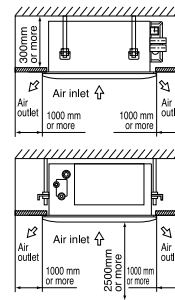
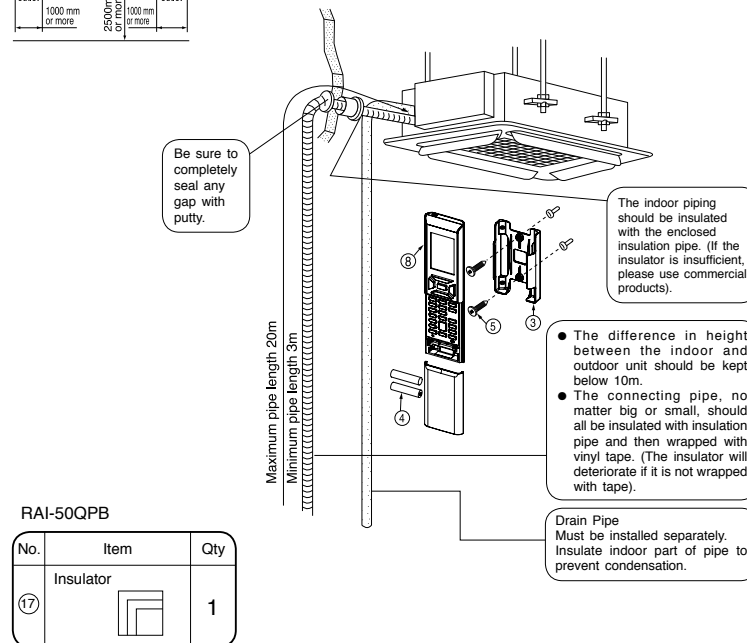

Figure showing the Installation of Indoor Unit.

CAUTION

- The installation height of indoor unit must be 2.3m ~ 3m.



RAI-50QP

No.	Item	Qty
⑰	Insulator	1

1 Opening on ceiling and suspension bolt

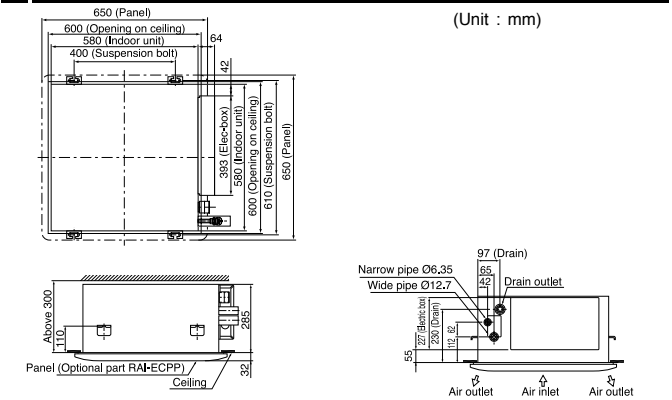

- Need a connecting work for refrigerant pipe, drain pipe and connecting cable in the ceiling after suspending the indoor unit. Arrange drain pipe, refrigerant pipe and connecting cable in their installation position.
- For finishing of opening on ceiling, arrange with builder in detail.
- If ceiling is already completed, connecting cables between indoor and outdoor, piping and drain piping must be done before fitting indoor unit.

2 Preparation for installing indoor unit

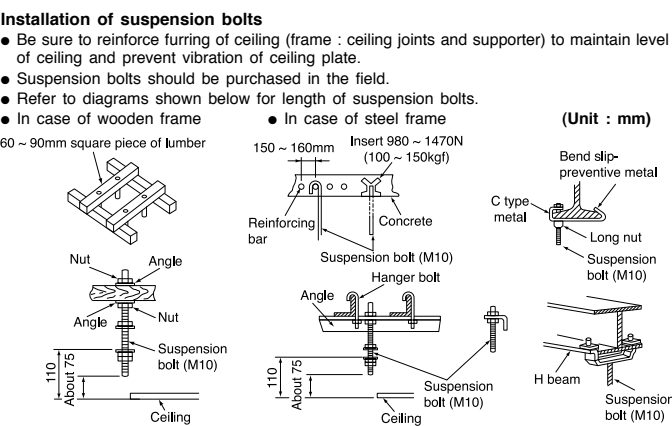

Wall Penetration and Installation of Protection Pipe

- Drill a ø 65mm hole on wall which is slightly tilted towards the outdoor side. Drill the wall at a small angle.
- Cut the protection pipe according to the wall thickness.
- Empty gap in the sleeve of protection pipe should be completely sealed with putty to avoid dripping of rain water into the room.

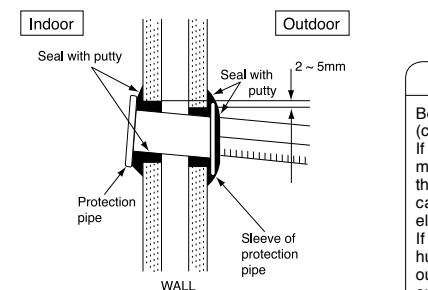

CAUTION

Be sure that the wire is not in contact with any metal in the wall. Please use the protection pipe as wire passing through the hollow part of the wall so as to prevent the possibility of damaged by mouse.

WARNING

Be sure to use protection pipe (commercial product). If connecting cables are touching metal lath inside the wall or inside the wall is hollow where mouse can bite cables, it can cause electrical shock or fire. If sealing is not complete, high humid air from inside the wall or outside of the room can come in and cause water dripping.

Drain pipe installation

- Use PVC pipe VP20 (O.D. 26mm) for drain pipe.
- Be sure to roll an insulation (thickness 10mm or more) for the drain pipe at indoor side.
- Always draw the drain pipe downward so that water flows smoothly. Fix it (ex. by hanger) to prevent a peak and trap.

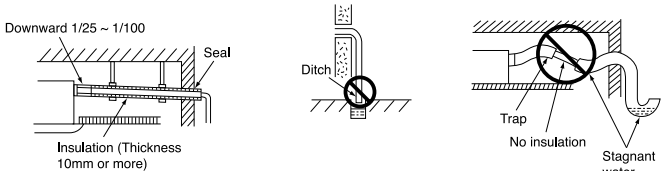

- In case drain piping cannot be done smoothly due to obstacles, it can also be arranged outside of the main unit as shown in the drawing below.

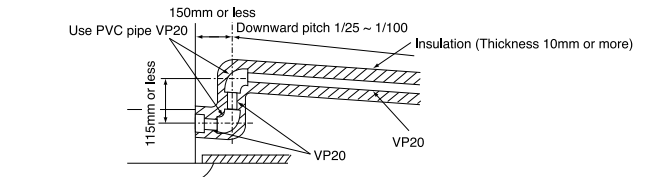

3 Installation of indoor unit

- Set nut and washer on suspension bolt and hook it to suspension clamp by lifting the indoor unit.
- Suspension bolt must have play of 20-30 mm on its right and left. If cannot have enough play, fix lifting lug to suspension bolt without attaching nut underneath the suspension bolt, then attach nut and install indoor unit.
- Make sure that indoor unit is kept level using a level.

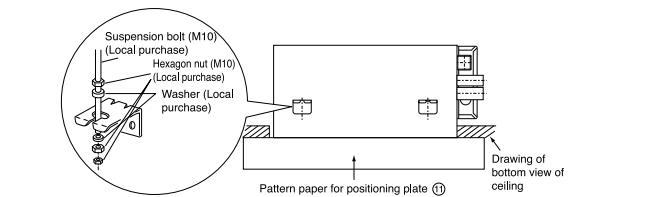

The space between bottom surfaces of ceiling and indoor unit

- Be sure to install the indoor units as follow position (1).
- Do not install the indoor units as follows position (2) (3).

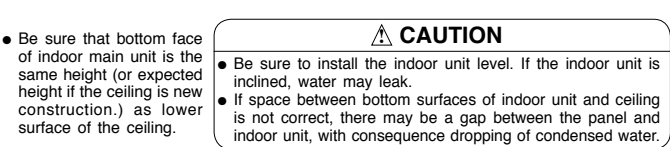

- Be sure that bottom face of indoor main unit is the same height (or expected height if the ceiling is new construction.) as lower surface of the ceiling.

CAUTION

- Be sure to install the indoor unit level. If the indoor unit is inclined, water may leak.
- If space between bottom surfaces of indoor unit and ceiling is not correct, there may be a gap between the panel and indoor unit, with consequence dropping of condensed water.

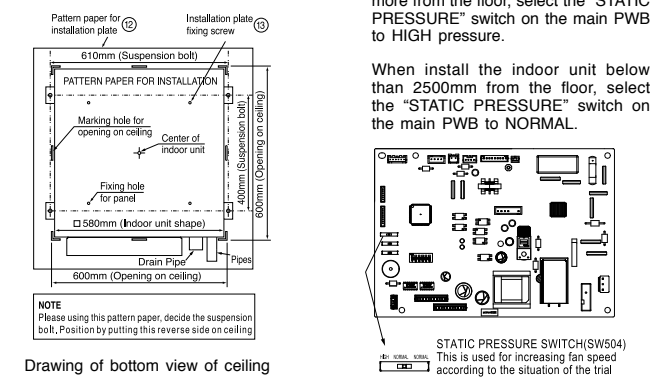

Selecting the Mounting Position

The installation place is very important for the air conditioner because it is very difficult to move from one place to another after the first installation. Decide the mounting position together with the customer. The discharge direction can be selected as shown below.

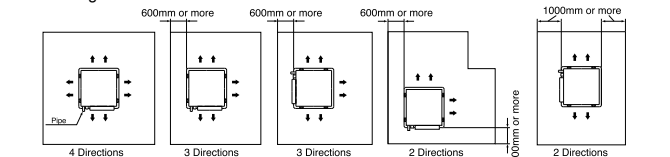

CAUTION

Since 2-way outlet as shown below causes performance problems, do not set it.

Blower cover installation

Install the blower cover only to the air outlet direction which is not in use. Install the blower cover at the diffuser position shown. Fix the blower cover certainly.

Corner seal installation

Install the corner seal at position shown. Fix the corner seal certainly. Shall be installed disregard to 2 directions, 3 directions or 4 directions.

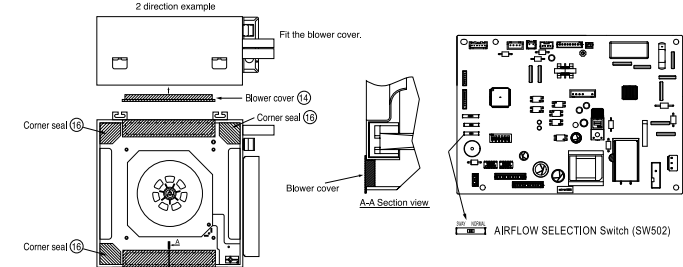

Selecting the switch

- 1 Turn OFF power supply.
 - 2 Remove cover of the electrical box.
 - 3 When selecting discharge direction of 2 directions or 3 directions, select the "AIR FLOW SELECTION" on the main PWB to 3 way.
- When selecting discharge direction of 4 directions, select the "AIR FLOW SELECTION" on the switch PWB to NORMAL.

NOTE: During 2 directions or 3 directions, sound level will increase.

4 Connecting the pipe

Connecting the pipe to the indoor unit

Remove the flare nut and seal cap. By loosening the flare nut at the pipe end, the refrigerant is discharged in a small amount. The arrangement has been made for shipment, and the discharge of refrigerant is never a trouble to the equipment. When the flare nut is removed, never fail to remove the seal cap. If not removed, the refrigerant will not be circulated, which result the compressor drive motor will possibly be burnt. Apply refrigerator oil to the union and the flared portion of the pipe. Wrap flare insulation, bind top and bottom flare insulation by binder.

CAUTION

When connecting pipes, if flare nut is over-tightened at the small diameter side, the screw thread of the service valve may be broken making pipe connection impossible. Be sure to tighten the nut with specified torque.

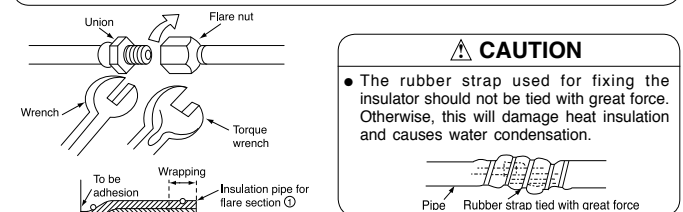

CAUTION

- The rubber strap used for fixing the insulator should not be tied with great force. Otherwise, this will damage heat insulation and causes water condensation.

Connecting of drain pipe

- Securely glue connection part of drain hose and PVC pipe, using PVC adhesive.
- If gluing of drain hose and PVC pipe is too weak, water leakage may occur. Be sure to wrap generally-available insulator (10mm or more of foamed polyethylene) around drain hose, inside the house, for insulation heat.
- Checking drain and water leakage. Perform after connecting power.
- If checking of drainage is omitted, water check may occur.
- Add water to water pan of indoor unit as shown below.
- Perform test running of drain pump to check drainage operation.
- Test run method
 - 1 Turn OFF power supply.
 - 2 Remove cover of electric box and set the drain pump test run switch to TEST.
 - 3 After checking the drainage, return the switch to NORMAL.

CAUTION

- If drain pump test run is right set to TEST, drain pump may malfunction.

1 Preparation of Pipe

- Use a pipe cutter to cut the copper pipe.

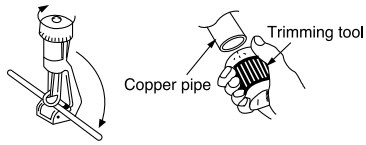

CAUTION

- Jagged edge will cause leakage.
- Point the side to be trimmed downwards during trimming to prevent copper chips from entering the pipe.
- Before flaring, please insert the flare nut into the pipe.



2 Pipe Connection

- Please be careful when bending the copper pipe.
- Applied frozen grease to the connection points and then screw in manually. After that, use a torque wrench to tighten the connection.

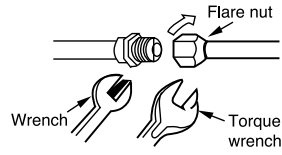

	Outer dia. of pipe	Torque N-m (kgf · cm)
Small dia. side	6.35 (1/4")	14.0 - 18.0 (140 - 180)
Large dia. side	9.52 (3/8")	33.0 - 42.0 (330 - 420)
	12.70 (1/2")	50.0 - 62.0 (500 - 620)
	15.88 (5/8")	63.0 - 77.0 (630 - 770)
Valve head cap	Small dia. side	6.35 (1/4") 19.6 - 24.5 (200 ~ 250)
	Large dia. side	9.52 (3/8") 19.6 - 24.5 (200 ~ 250) 12.7 (1/2") 29.4 - 34.3 (300 - 350)
Valve core cap		12.3 - 15.7 (125 ~ 160)

Outer Diameter mm (inch)	Thickness (mm)	A (mm)		
		Flare tool for R410A Clutch type	Conventional flare tool Clutch type Wing nut type	
6.35 (1/4")	0.8	0.0 ~ 0.5	1.0 ~ 1.5	1.5 ~ 2.0
9.52 (3/8")	0.8	0.0 ~ 0.5	1.0 ~ 1.5	1.5 ~ 2.0
12.70 (1/2")	0.8	0.0 ~ 0.5	1.0 ~ 1.5	1.5 ~ 2.5
15.88 (5/8")	1.0	0.0 ~ 0.5	1.0 ~ 1.5	1.5 ~ 2.5

3 Removal Of Air From The Pipe And Gas Leakage Inspection

AIR REMOVAL

Procedures of using Vacuum Pump for Air Removal

- As shown in right figure, remove the cap of valve core. Then, connect the charge hose. Remove the cap of valve head. Connect the vacuum pump adapter to the vacuum pump and connect the charge hose to the adapter.
- Fully tighten the "Hi" knob of the manifold valve and completely unscrew the "Lo" knob. Run the vacuum pump for about 10-15 minutes, then completely tighten the "Lo" knob and switch off the vacuum pump.
- Remove the charge hose and tighten the cap of valve core. Check the cap's periphery if there is any gas leakage.
- Completely unscrew the spindle of the service valve (at 2 places) in anti-clockwise direction to allow the flow of refrigerant (using Hexagonal Wrench key).
- Re-cap the service valve and tighten using wrench. Check the cap's periphery if there is any gas leakage. The task is then completed.

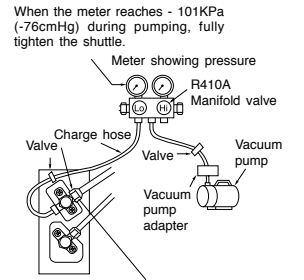

When the meter reaches - 101KPa (-76cmHg) during pumping, fully tighten the shuttle.

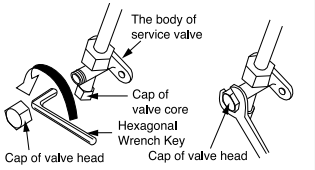

When pumping starts, slightly loosen the flare nut to check of air sucked in. Then tighten the flare nut.

Gas Leakage Inspection

Please use gas leakage detector to check if leakage occurs at the connection of Flare nut as shown on the right.

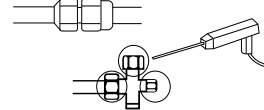

If gas leakage occurs, further tighten the connection to stop leakage. (Use the detector provided for R410A)

CAUTION

In case of removing Flare nut of a indoor unit, first remove a nut of small diameter side, or a seal cap of big diameter side will fly out.

WARNING • THIS APPLIANCE MUST BE EARTHED.

Power supply shall be connected at the rated voltage, otherwise the unit will be broken or could not reach the specified capacity.

Procedures of Wiring

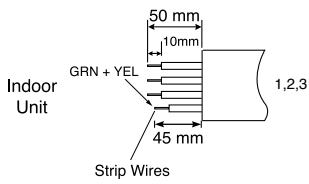

Wiring Of The Indoor Unit

- Remove the cover of the electric box.
- Connect the connecting cords.
- Assemble the cover of electric box.

Insert and fix the connecting cords with screw. Connect the earth cord.

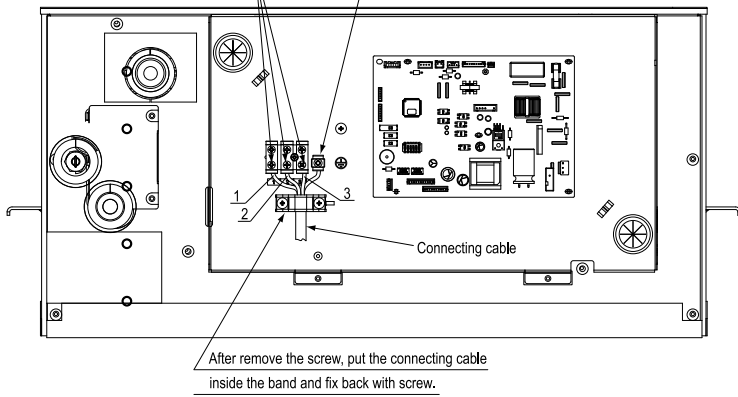

WARNING

- The naked part of the wire core should be 10 mm and fix it to the terminal tightly. Then try to pull the individual wire to check if the contact is tight. Improper insertion may burn the terminal.
- Be sure to use only power cables approved from the authorities in your country. For example in Germany: Cable type: NYM 4 x 1.5mm².
- Please refer to the installation manual for wire connection to the terminals of the units. The cabling must meet the standards of electrical installation.
- There is a AC voltage of 220-240V between the 1 and 2 terminals. Therefore, before servicing, be sure to remove the plug from the AC outlet or switch off the main switch.

Checking for the electric source and the voltage range

- Before installation, the power source must be checked and necessary wiring work must be completed. To make the wiring capacity proper, use the wire gauge list below for the wiring from a switch board of fuse box to the outdoor unit in consideration of the locked rotor current.

IMPORTANT

Cable length	Wire cross-section
up to 25m	1.5mm ²

How To Connect The Optional Parts
(WiFi Adaptor, RAC Adaptor, Wired Remote Controller, Dry Contact)

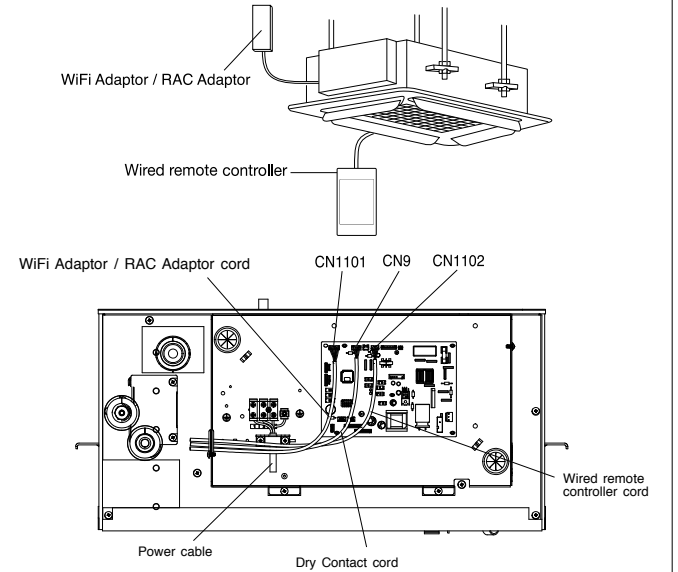

- To connect to H-LINK, a separately purchased RAC Adaptor is required.
- To connect to Dry Contact, a separately purchased Dry Contact Connection Cord is required.
- To connect Wired Remote Control, a separately purchased Wired Remote Control is required.
- To connect to WiFi, a separately purchased WiFi Adaptor is required.

- To install the wiring, remove the metal cover of electrical box.
 - As for Dry Contact, connect the connection cord to CN9.
 - As for WiFi Adaptor or RAC Adaptor, connect the connection cord to CN1101.
 - As for Wired Remote Control, connect the connection cord to CN1102.
- The connection cords and power cable are to be arranged and tied up as per the diagram as shown above.
- Please refer to the respective user manual of the Dry Contact, WiFi Adaptor, RAC Adaptor and Wired Remote Controller for further details.
- Please refer to user manual for instructions on removal and installation of the electrical box.
- Please be careful not to damage lead wires by edge of metal plate when connecting the optional parts.
- For ordering all optional parts, please refer to the catalogue for part number.

1 Insulation And Maintenance Of Pipe Connection

- The connected terminals should be completely sealed with heat insulator and then tied up with rubber strap.
- Please tie the pipe and power line together with vinyl tape as shown in the figure showing the installation of Indoor and Outdoor units. Then fix their position with holders.
- To enhance the heat insulation and to prevent water condensation, please cover the outdoor part of the drain hose and pipe with insulation pipe.
- If room humidity is high, cover the connecting pipe with additional 5mm thickness insulator. This insulator shall be purchased from field.
- Completely seal any gap with putty.

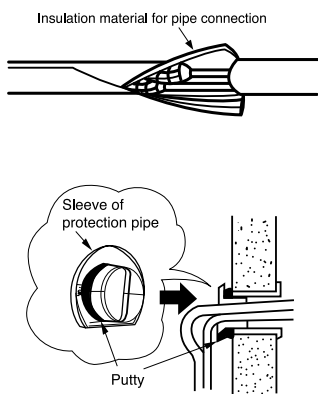

2 Installation Of Remote Controller

- The remote controller can be placed in its holder which is fixed on wall or beam.
- To operate the remote controller at its holder, please ensure that the unit can receive signal transmitted from the controller at the place where the holder is to be fixed. The unit will beep when signal is received from the remote controller. The signal transmission is weakened by the fluorescent light. Therefore, during the installation of the remote control holder, please switch on the light, even during day time, to determine the mounting location of the holder.

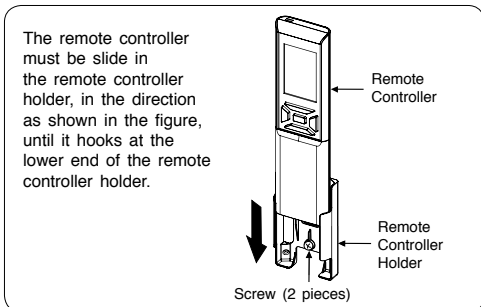

3 Power Source And Operation Test

Power Source

CAUTION

- Please make sure, that the power voltage is 220V-240V within the operation voltage of the unit.
- Please take under consideration, that the power capacity from your house distribution box is high enough for operating your room air conditioner.

Operation Test

- Please ensure that the air conditioner is in normal operating condition during the operation test.
- Explain to your customer the proper operation procedures as described in the user's manual.

4 Installation Of Optional Panel

- Carefully read through the procedures of proper installation before starting installation work.